

Primatech

P250A

**PNEUMATIC FLOORING TOOL
OPERATING INSTRUCTIONS**

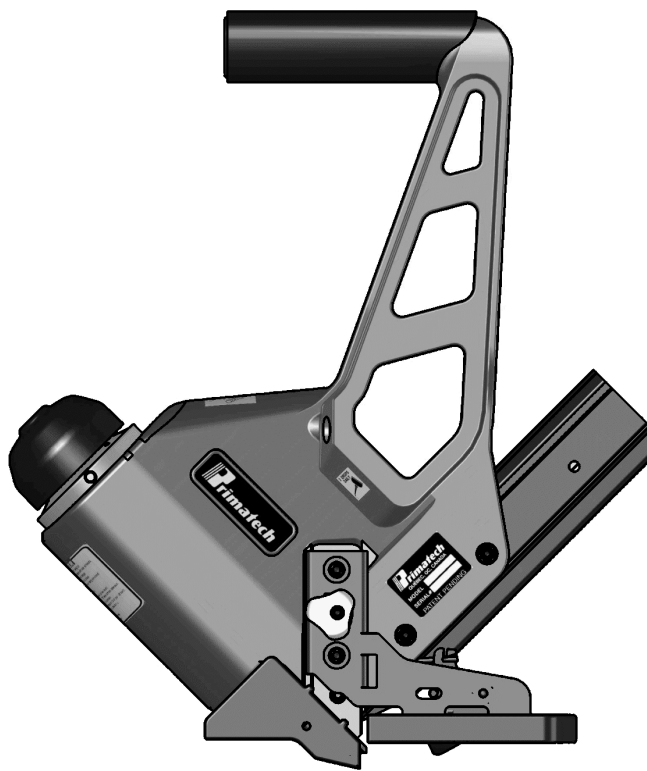

WARNING

Read these instructions thoroughly before using this tool and keep it handy for reference.

PRIMATECH PNEUMATIC TOOL P250A

The pneumatic flooring tool P250A is a professional precision tool specially developed for the installation of 5/8" to 7/8" solid hardwood flooring in standard version, or from 3/4" to 33/32" for the GYM-version. It has been designed for easy maintenance where major components can be accessed within seconds without the need of any tool. Weighting only 11 pounds (5 kg), this ergonomically designed tool makes the installation of hardwood floor very easy, allowing the operator to set and fasten the boards in the standing position. It is offered in 3 different configurations:

- standard L-type 16GA nails in lengths of 1½" (38 mm), 1¾" (45 mm) or 2" (50 mm)
- T-type 16GA nails in length of 1½" (38 mm) or 2" (50 mm)
- ½" crown 15½GA staples in lengths of 1½" (38 mm), 1¾" (45 mm) or 2" (50 mm)



The P250A is built around the **Primpact** valve engine, a breakthrough technology for pneumatic tools. Primpact main features are:

- short nose and compact valve design with an all-around striking surface
- high-speed action and few moving parts, for a powerful yet soft stroke and increased precision.
- reciprocal striking system that regulates the depth of penetration independently from the mallet impact
- finely threaded screw-in cartridge assembly

For best result, only PRIMATECH fasteners should be used. Read carefully these instructions before operating this tool. It is important to understand warnings/cautions and the safety measures to ensure safe use of this tool.

Additional information is available directly from the manufacturer:



1135 Jérémie-Fortin, Québec, QC
Canada, G1J 1R8

Phone: 1 (800) 363-1962 or 1 (418) 522-7744

Fax: 1 (418) 522-7466

email: support@primatech.ca

web: <http://support.primatech.ca>

SAFETY MEASURES

These important guidelines should always be followed to work safely with the PRIMATECH pneumatic tool model P250A:

- Read these instructions thoroughly before using this tool and keep it handy for reference if necessary.
- Always keep hands, feet or other body parts away from the fastener ejection area.
- Never aim the tool in any direction other than the working area.
- Always carry or manipulate the tool by its handle while the air supply hose is connected.
- Never hit the head cap of the actuator if the plastic base is not sitting perfectly on the working surface.
- Never leave the tool laying down on its side while the air supply hose is connected; the tool should always be left on the floor, standing on its plastic base.
- Do not alter or remove safety.
- Always disconnect the air supply hose when the tool is not in use or when move to another work area.
- Never service or repair the tool, clear obstructions or make adjustments while the air supply hose is connected.
- Only compressed air should be used to power this tool; do not exceed 110 psi (7.6 bar).
- Never use oxygen or any other compressed gas as a power source for this tool. Explosion may occur.
- Always wear OSHA-required Z-87 safety glasses with side shields.
- Always wear proper ear and foot protection while the air supply hose is connected.
- Always remove fasteners from the magazine before servicing tool.



DO NOT REMOVE OR ALTER SAFETY. DO NOT USE A TOOL WITH A DEFECTIVE SAFETY. NEVER DEPRESS THE SAFETY CONTACT WITH YOUR HANDS WHEN TOOL IS CONNECTED TO AIR SUPPLY. EXTREME CAUTION IS ADVISED WHEN USING THIS TOOL.

Eye protection is recommended and should be worn by the operator and other in working area. Accidental ejection of fasteners or wood debris could cause severe eye injury.



In some environments, ear protection might be required, as working condition may include exposure to high noise levels which lead to hearing damage.



Wearing safety boots and safety hat is also highly recommended.



NOTE: All the personal protection equipments must meet national standards.



CONNECTION & AIR SUPPLY SYSTEM

To ensure maximum performance and efficiency, and also a minimum of care, this tool requires clean & dry air. The use of a filter and a pressure regulator is recommended.

This tool needs a detachable male coupler with 3/8" NPT male threads. The use of a 3/8" (1 cm) diameter air supply hose is recommended. A smaller hose or a hose longer than 50' (15 m) could cause a pressure drop when the tool is activated repeatedly.



ALWAYS USE A FREE-FLOW CONNECTION FOR THE COMPRESSED AIR SUPPLY TO PREVENT THAT THE TOOL STAYS CHARGED AFTER DISCONNECTING THE AIR SUPPLY HOSE.



UNLOAD TOOL BEFORE CONNECTING AIR TO PREVENT ACCIDENTAL DISCHARGE.



AFTER MOVING TOOL TO A DIFFERENT WORK AREA, OR AFTER ANY MAINTENANCE TO THE TOOL, ALWAYS ENSURE PROPER OPERATION BY ACTUATING TOOL SEVERAL TIMES WITHOUT FASTENERS OVER THE SUBFLOORING .

Dirt, dust, and other particles in the air supply can cause sluggish operation or premature wear of many components of the tool. Drain water from the compressor tank regularly. The compressor start-stop limits should be set to deliver an air pressure of at least 100 psi (7 bar) at all times. Consult the compressor manual or dealer for instructions on how to make this adjustment.

At 80 psi (5.5 bar) and 40 hits per minute, this tool consumes approximately 1.9 cu.ft (50 l) of air per minute at 70EF (21EC). Higher air pressure will increase the consumption of compressed air.

This tool is designed to be operated with a compressed air pressure of 80 to 100 psi (5.5-7.0 bar). Air pressure of 90 psi (6.2 bar) is adequate for most situations, although occasionally, a higher pressure could be necessary. Always use the tools at minimum operating pressure in order to avoid unnecessary high noise level. In these more difficult cases, the compressed air pressure can be increased up to 100 psi (7.0 bar). It is very important not to exceed this maximum pressure to prevent leaks, premature wear or damages to the tool.

Check the compressed air supply hose before connecting to ensure that it is free from dirt or particles that can alter the performance of the tool. Pay special attention to any air leaks. Do not use a compressed air pressure higher than 110 psi (7.6 bar). Higher pressure can cause premature wear or damage to certain components. After assembly, check all the connections to prevent the leaks and to have maximum efficiency.



TO PREVENT ACCIDENTAL DAMAGE TO THE FINISHED SURFACE OF THE INSTALLED FLOOR, REST THE TOOL ONTO THE SUBFLOORING WHEN CONNECTING AIR, LOADING TOOL OR PERFORMING ANY MAINTENANCE TO THE TOOL.

LOADING THE TOOL

This tool comes in one of 3 different configurations:

- L-type 16ga nails in lengths of 1½" (38 mm), 1¾" (45 mm) or 2" (50 mm)
- T-type 16ga nails in lengths of 1½" (38 mm) or 2" (50 mm)
- ½" crown 15½ga staples in lengths of 1½" (38 mm), 1¾" (45 mm) or 2" (50 mm)



USE ONLY THE TYPE OF FASTENERS IDENTIFIED ON THE MAGAZINE. THE USE OF ANY OTHER TYPE OF FASTENERS WILL DAMAGE THE TOOL.

P250AL – Loading the tool with L-type 16ga nails:

This tool is fitted with the **LOADXTEND** technology. Its automatic magazine holds & feeds 200 nails (2 strips) in an assembly no longer than a conventional one. Its exclusive pusher locks into a pre-armed position, allowing nails to be fed by gravity until it automatically engages behind. To load the tool:

- Insert one or two rows of flooring nails into the back end of the magazine.
- Pull the pusher back completely and release it until it locks in position or engages behind the nails.
- To remove nails from the magazine, simply squeeze the pusher with your thumb and index finger and allow it to recoil slowly. You can then slide out remaining nails.

P250AT – Loading the tool with T-type nails:

- Insert a row of T-type nails into the back end of the magazine.
- Pull back on the pusher until it engages behind the nails.
- To remove nails from the magazine, simply squeeze the pusher with your thumb and index finger and allow it to recoil slowly. You can then slide out remaining nails.

P250AS – Loading the tool with flooring staples:

- Pull the pusher back completely until it tilts to lock in position.
- Insert strips of flooring staples into the top of the magazine.
- Pull and tilt the pusher to release it from its lock position and engage it behind the staples.

ADJUSTING FOR HARDWOOD THICKNESS

The P250A pneumatic tool is fitted with a fully adjustable plastic base designed to prevent contact with the top edge of the flooring. It is important to adjust the tool to fit the flooring prior any installation. It also features a resting block which prevent damage to the top edge of the flooring by positioning the tool against the tongue, preventing the gate/foot assembly from contacting the board.

Step 1: adjusting the base for flooring thickness:

- Using the supplied Allen wrench, loosen but do not remove screws (A); two on each side of the tool.
- With the tool in an upside down position, place a short piece of flooring against the gate/foot assembly.
- Engage the Allen wrench in knob (B) as shown; rotate to move the base up or down. Note that knob (B) has a rotation range of only about 1/2 turn. Do not apply force when a limit is reached.
- Adjust the height of the plastic base to obtain a small gap between the gate/foot assembly and the top side of the tongue of the sample board. A gap of 1/32" should be adequate for most situations.
- Tighten both screws (A).

Step 2: adjusting the resting block for the width of the tongue:

- Using the Allen wrench, loosen by about 1/2 turn — do not remove the two screws (C).
- With the short piece of flooring still against the gate/foot assembly, adjust the gap between the resting block and the tongue with screw (D). A small gap of 1/32" should be adequate for most situations.
- Tighten both screws (C).
- Ensure that screw (D) is slightly tighten. Do not apply force on screw (D) once screws (C) are tighten.

After completing the adjustment procedure, proceed with the installation of few boards. Carefully check for the proper positioning of the fastener onto the board. Check again after few more rows to insure that all parts are secured in place. Tool may lose adjustment over time if this procedure is not strictly followed.



BEFORE STARTING AN INSTALLATION, FASTEN DOWN FEW BOARDS TO ASCERTAIN THAT YOU ARE USING THE RIGHT TOOL AND FASTENER.

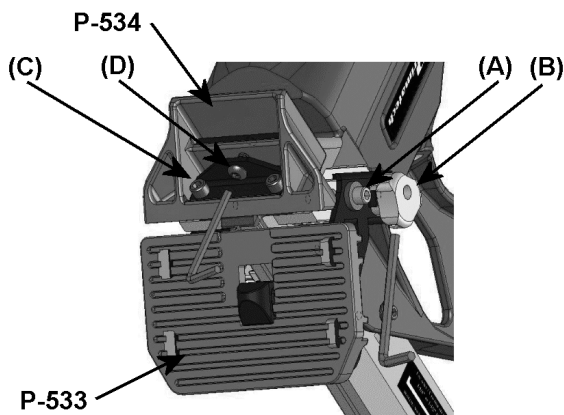

ADJUSTING ROLLER BASE

The P250A can be mounted on a roller base (standard on P250AR & P250AG).

Step 1: adjusting the back rollers for flooring thickness:

- Using the 3/16" wrench, unfasten but do not remove screws (A), on each side.
- Put the tool upside down and position a short piece of flooring against the gate/foot assembly.
- Engage the 3/16" wrench in knob (B) as shown; rotate to move the base up or down. Note that the rotation range is only about 1/2 turn, do not apply unnecessary force when a limit is reached.
- Adjust the height of the base to obtain a small gap between the gate/foot assembly and the top side of the tongue of the sample board. A gap of 1/32", about half the thickness of the nail, should be adequate for most situations.
- Tighten both screws (A).

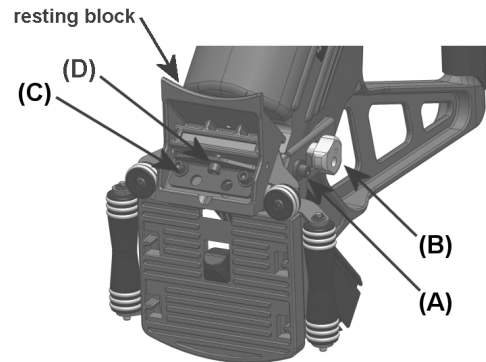

Step 2: adjusting the resting block for the width of the tongue:

- The front rollers are always in contact with the front edge of the board. It is necessary to adjust the resting block to maintain a small gap between it and the tongue of the board.
- Using the 3/16" wrench, loosen screws (C) about 1/2 turn — do not remove.
- With the short piece of flooring still against the gate/foot assembly, adjust with screw (D) the gap between the resting block and the tongue. A small gap of 1/32", about half the thickness of the nail, should be adequate for most situations.
- Tighten both screws (C).

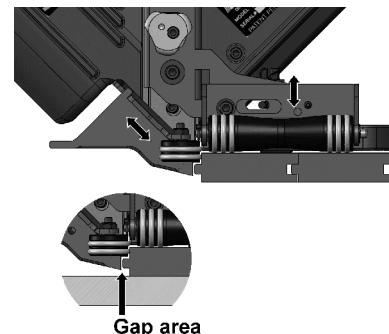

OPERATION

Unload tool and rest it onto the subflooring. Connect the hose and cycle tool once or twice without fastener. After loading the tool, the tool is ready for use.

Use only the 2.5 lbs (1.1 kg) hammer supplied with the tool. The use of other type of hammers may affect performance. The rubber face of the hammer can be used with care to help position the boards.

With the flooring firmly in place, position the tool onto the flooring, with the resting block P-534 against the tongue. Apply downward pressure to ensure proper seating of the fastener. Strike the head cap with the hammer to activate the tool. **Use only the RUBBER FACE of the hammer to activate the tool. Using the steel end will damage the tool and void the warranty.** If wood is slightly twisted, hitting the tool with more force will assist in pulling the board up snugly. **NEVER** strike the head cap when the tool is not sitting on the working surface.



OPERATING THE TOOL WHEN THE SAFETY CONTACT IS NOT FULLY DEPRESSED WILL CAUSE PREMATURE WEAR OR DAMAGE TO THE DRIVING BLADE, PISTON AND CYLINDER.

Be it raw, factory finished or engineered, hardwood is a natural material subject to various factors, such as humidity, subflooring, installation procedure, type of tools, fasteners, etc. Installer should always ensure optimal surface preparation, comply with all manufacturers recommendations and conduct a pre-installation test prior to beginning any installation.



BEFORE STARTING AN INSTALLATION, FASTEN DOWN FEW BOARDS TO ASCERTAIN THAT YOU ARE USING THE RIGHT FASTENER AND THAT THE TOOL IS PROPERLY ADJUSTED.

MAINTENANCE & REPAIR

Most adjustments to the tool can be made with the 3/16" Allen wrench supplied with the tool.

Disassembly of the tool must be done in a clean environment. Some parts can be easily damaged if disassembled with improper tools or by inadequate methods. Maintenance should only be performed by trained personnel. Use only genuine PRIMATECH replacement parts.



TO PREVENT INJURY, ALWAYS DISCONNECT THE AIR SUPPLY HOSE WHEN SERVICING OR DISASSEMBLING THE TOOL.

When servicing the tool, do not twist or force any parts. Damage may result from such abuse. If parts do not come loose easily, contact your PRIMATECH distributor for more information.

When opening the tool for maintenance, always clean all components of dirt, grit, or particles. Inspect the tool carefully for broken parts or excessive wear, and replace if necessary. When ordering parts, be sure to specify the right part number, as well as the tool serial number.



AFTER ANY MAINTENANCE TO THE TOOL, REMOVE ALL FASTENERS BEFORE CONNECTING AIR AND ACTUATE THE TOOL REPEATEDLY OVER A PIECE OF WOOD OR SUBFLOORING TO INSURE PROPER OPERATION.